

AIR SCRUBBER

MAS 13

230 V - 50 Hz



FUNCTIONING PRINCIPLES

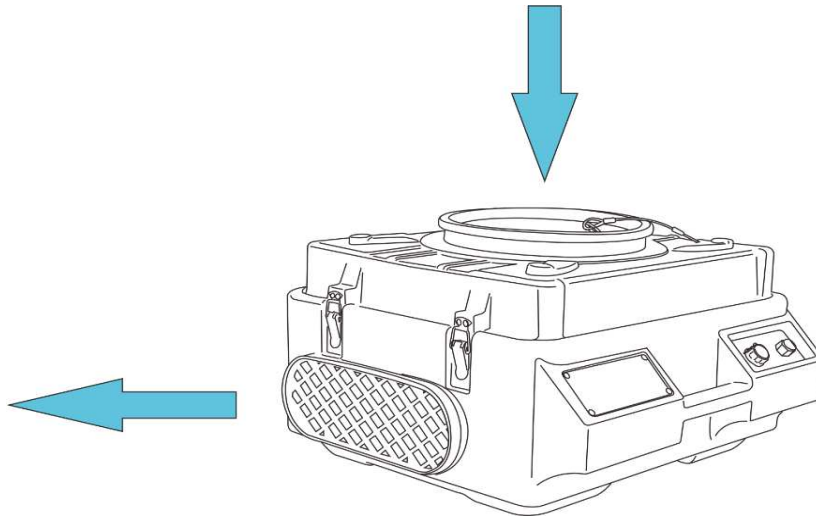

The air flow is forced with plug fan through two types of filters: first the G4 filter and in second way the HEPA filter H13.

TECHNICAL DATA

Max capacity	kW Kcal/h Btu/h	0,23	Power supply	V	220-230
Combustible		/	Frequency	Hz	50
Net weight	kg	13,5	Rated current	A	1
Gross weight	kg	15			
Noisy level	dBa	68			
Air displacement	m ³ /h	1300			

PACKING

Dimensions packing	mm	580 x 380 x 620
Dimensions utilization	mm	560 x 360 x 600
Pieces for Euro-pallet	n°	18
Pieces per truck 80m ³	n°	594

COMPONENTS

Motor

Asynchronous monophas 2400 rpm

ACCESSORIES

Hour counter

WIRING DIAGRAM

